

POWER DISTRIBUTION UNIT: POWERPAK RPP SERIES

ADVANCED POWER DISTRIBUTION SYSTEMS

WIN THE RACE FOR SPACE Today's peripheral devices are decreasing in ampacity while increasing in quantity. Although your PDUs may still be able to handle the power demands of your growing facility, they may not have room for expansion. PDI's Remote Power Panel (RPP) helps you win "the race for space" by providing the added pole "space" to meet your distribution needs without consuming valuable floor "space".

A freestanding device, the RPP allows you to effectively use all of your existing capacity before investing in additional distribution. To "expand" your system, simply connect the RPP to any standard subfeed circuit breaker of a PDU or 208V distribution board.

SIMPLIFIED EXPANSION

- Reduces the length of cable runs between your PDU and the individual loads
- Optimizes usable floor space
- Simplifies server consolidation plans
- Meets the growth demands of dual cord equipment
- Retrofits to any existing distribution system
- Minimizes your investment risk today by allowing for incremental expansion of your future facility

FLEXIBLE PACKAGING Designed in an aesthetically pleasing cabinet to match the high-tech look of today's computer centers, the RPP's flexible configuration options allow it to grow with your facility. The RPP can function as a stand alone device or as part of an extensive distribution system. You can choose a single input device or dual power feeds to satisfy system redundancy and maintenance requirements. All RPP designs can be packaged to allow for system expansion without interruption to your loads. Each unit can be equipped with any custom monitoring package you require for your system.

ASSURED PERFORMANCE PDI's complete line of PowerPak technology has long delivered superior performance and protection for your computer systems and equipment. The newest member of the family, the RPP Series, allows for flexible expansion of your computer room and reflects PDI's many years of experience in the power quality and distribution industry.



POWER DISTRIBUTION UNIT: POWERPAK RPP

SPECIFICATIONS

RATINGS

- Input: 225 amp, 240 volt
- Input: 3-phase, 4 wire plus ground
- Input/Output Voltage @ 60 Hz: 208/120 Volts (consult factory for other ratings)

FEATURES

- 3 pole, 225 amp, 240 volt rated input molded case switch
- Up to four (4) 42 pole distribution panelboards
- Oversized neutral for non-linear loads
- Single point isolated ground (optional)
- Single point equipment ground
- UL Listed

ENCLOSURE

- Compact footprint measuring 24" wide x 24" deep
- Freestanding enclosure
- Removable top, side and rear panels
- Keyed door lock
- Full front inner hinged panelboard cover
- Suitable for top or bottom entry
- CE Listed cabinet
- Vision panels

POWERPAK RPP SERIES OPTIONS

BRANCH CIRCUIT MONITORING SYSTEM

Measures and reports the current of each individual panelboard circuit. Please consult PDI's Branch Circuit Monitoring System Technical Guide for further product information.

BRANCH CIRCUIT BREAKERS

Plug-in or bolt-on circuit breakers for individual circuit distribution. Available in a variety of configurations.

MAIN INPUT CIRCUIT BREAKER

The main input circuit breaker replaces the standard input molded case switch.

TRANSIENT SUPPRESSION NETWORK (TSN)

An integrated system designed and engineered to meet ANSI/IEEE category C standards for transient voltages and surge currents.

UL LISTED POWER CABLES

PDI's UL listed computer power cables are designed and tested to ensure reliability and proper grounding in a flexible, steel conduit complete with a copper shield wound into the conduit itself. Available in a variety of configurations.

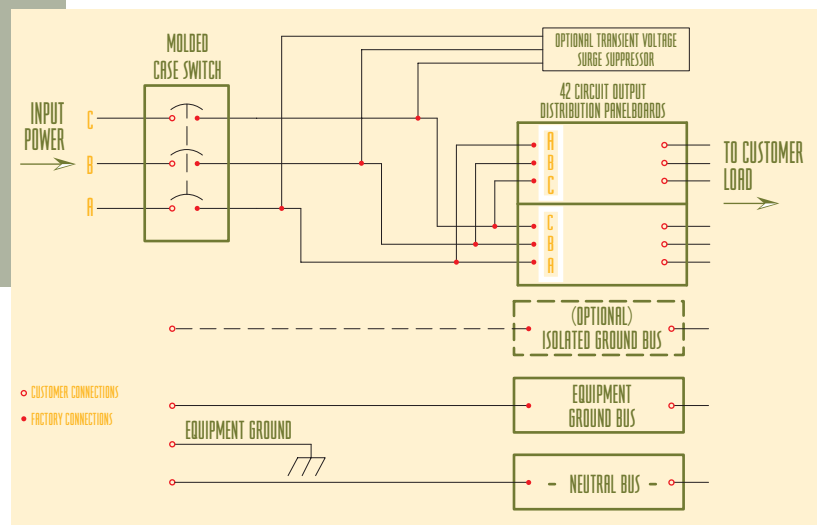

PDI
creating the perfect wave

Power Distribution, Inc.
4200 Oakleys Court
Richmond, VA 23223
800.225.4838
804.737.1703 fax
web site: www.pdicorp.com

25 years