

TOSHIBA
Leading Innovation >>>



G9000 >>>>
UNINTERRUPTIBLE POWER SYSTEMS

POWER & EFFICIENCY REDEFINE UPS PERFORMANCE STANDARDS

The Toshiba G9000 Series Uninterruptible Power System (UPS) utilizes state-of-the-art design and construction to deliver industry-leading efficiency, reliability, performance, and flexibility to meet today's critical power demands.



- Next-Generation Insulated Gate Bipolar Transistor (IGBT) Technology
- True On-Line, Double-Conversion UPS
- Input Power Factor > 0.99
- Input Current THD < 3%
- 100% Unbalanced Load Capability
- Wide Input Voltage Range +15%, -20% (Without Utilizing Batteries)
- High Efficiency for Lower Operational Cost
- Smallest Footprint & Highest Power Density in Industry
- Electronic Battery Isolation for Battery Longevity
- Generator-Friendly Design & Compatibility
- Complete Front-Access for Installation, Operation, & Service
- Handles Leading Power Factor Loads (Without Derating)
- SNMP/Web-Based Monitoring
- Three-Year Warranty for Lower Cost of Ownership

> SMALLEST FOOTPRINT WITH HIGHEST POWER DENSITY

- **A High Efficiency Design** separates the G9000 from the competition. Efficiency greater than 92.5% at 20% loading means lower power losses, reduced air conditioning needs, and reduced utility costs across a wide load range without sacrificing frequency or output voltage stability.
- **A Transformer-Less Design** allows the G9000 to be lighter with a smaller footprint. With its compact size, the G9000 has the highest energy density per square foot of any UPS of similar capacity.

> ADVANCED FEATURES FOR MAXIMUM PERFORMANCE

- **Fast-Switching IGBT Control Technology** delivers up to 97% efficiency.
- **A Full IGBT Rectifier & Harmonic Input Filter** reduce input total harmonic distortion (THD) which also reduces heat loss in associated feed equipment and increases component life.
- **An IGBT DC-to-DC Chopper** produces lower DC ripple on the charging circuit, extending battery and capacitor life.
- **A Hybrid Static-Bypass Switch** offers the highest level of dependability.
- **Improved Output Voltage Regulation** provides superior transient response, easily handling 100% step loads without requiring battery support.
- **A Generator-Friendly Design** allows sizing of 1.1 kW generator capacities per 1.0 UPS kVA load.
- **Robustly Engineered Units** are built using the highest quality components to ensure reliability.

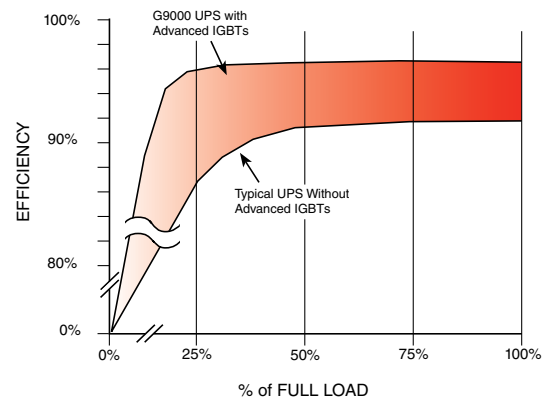

> ANCILLARY OPTIONS

VRLA and Toshiba lithium titanate SCiB™ Rechargeable Batteries are two energy storage options compatible with the G9000 Series UPS. The robust recharge circuitry of the G9000 allows use of VRLA batteries in matching cabinets or wet cell batteries without requiring a supplemental charger.

The G9000 UPS Tie Cabinet provides a simple and economical landing point for a multi-module G9000 system's output. Toshiba's solution is a smaller, lighter option with no control electronics compared to those offered by competitors. An optional 15-inch color LCD display is available for centralized monitoring of module and system status as a supplement to individual module monitors.

Maintenance Bypass Cabinets are available in wall-mount and stand-alone versions, as well as a custom designed slim-line version that matches the height and depth of the G9000 to seamlessly blend with the UPS.

Optional Power Distribution Units (PDU) with internal 480/208 transformers and remote power panels (RPP) are available in a range of sizes and capacities.

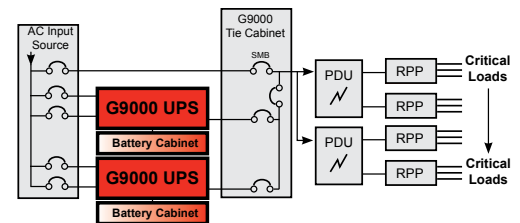

> MONITORING OPTIONS

RemotEye 4® interface offers remote monitoring and analysis of UPS operation via HTTP and SNMP.

- Detailed Real-Time Status of UPS
- Email Notification of Status & Events
- Event & Alarm History Logging
- Remote Control of UPS via Internet
- SNMP
- Modbus/RTU
- Modbus/TCP
- BACnet MSTP
- BACnet IP
- AB EtherNet/IP
- Metasys N2

Hard-Wired Remote Status Alarm Panel (RSAP) enables remote-monitoring of UPS alarm/status points up to 1000 feet away.

> FACTORY WITNESS TESTING

Toshiba has a 3 MVA Witness Test Facility at its plant in Houston, Texas. For a low cost, customers can perform witness testing to validate their system's performance specifications in all operating modes prior to taking delivery.

Multi-module parallel configurations, including energy storage backup, can be assembled and tested in all modes before shipment for final installation.





▶ SERVICE PROVIDERS

Toshiba's growing network of more than 120 authorized service providers supply factory trained technicians to service and support Toshiba UPSs throughout the contiguous United States, Canada, Caribbean, Mexico, and Central & South America.

▶ MAINTENANCE AGREEMENTS

Three standard levels of maintenance agreement packages are available to provide the service support appropriate customer needs and budgets while maximizing the performance and life of the Toshiba UPS. Tailored, site-specific service agreements range from simple scheduled preventive maintenance programs to a Platinum Service Agreement with guaranteed response times, 24/7/365 coverage, and discounted replacement parts.

▶ PREVENTIVE MAINTENANCE

Derived mean time between failure (MTBF) rates are based on an ideal operating environment. Real operating environments vary from benign to outright hostile. Preventive maintenance will help ensure you get the maximum service out of your Toshiba system.

The maintenance needs of a G9000 Series UPS are minimal but crucial.

- Periodic inspection, calibration, and adjustment of the control and monitoring systems are necessary to ensure continued optimal performance and the highest level of reliability.
- Regular maintenance can help detect early signs of degradation in capacitors, fans, and other components, allowing for timely repair without the UPS unexpectedly failing. This is particularly important in harsh environments with excessive humidity, temperature extremes, frequent out-of-specification voltage excursions, and abrasive air particles.

▶ WARRANTY

The G9000 UPS and the accompanying energy storage system are supported by Toshiba's industry-leading three-year parts and labor warranty* and a 24/7/365 hotline. This ensures that customers get the quickest possible resolution to any warranty or service issues that may arise.

*Conditional to system startup by an authorized Toshiba UPS service provider. See three-phase warranty for details.



> 100 - 225 kVA

MODEL NUMBER	T90S3S10KS6XS2	T90S3S16KS6XS2	T90S3S22KS6XS2
Capacity (KVA/KW)	100/90	160/144	225/202.5
Topology	True On-Line, Double-Conversion, All-IGBT Technology		
INPUT			
Voltage (Standard)	480V Three-Phase, Three-Wire + Ground Dual Input		
Voltage Range	-20% to +15% (Without Using Battery)		
Power Factor	> 0.99		
Current THD	<3% at 100% Load		
Frequency	60 +/- 10% Hz		
OUTPUT			
Voltage (Standard)	480 V: Three-Phase, Three-Wire + Ground		
Frequency	60 +/- 0.01% Hz		
Voltage Regulation	+/-1%		
Power Factor	0.9 Lagging		
Power Factor Range	0.9 Lagging to 1.0 within kW rating		
Voltage THD	<2% at 100% Linear Load, <5% at 100% Non-Linear Load		
Overload Capacity	Inverter: 125% for 2 Minutes, 150% for 60 Seconds, Bypass: 1000% for 1 Cycle		
BATTERY			
DC Link	480 V		
ENVIRONMENT			
Temperature Range	32° to 104°F (0° to 40°C)		
Relative Humidity	5% to 95% Non-Condensing		
Heat Rejection	13.5 kBTU/Hour	17.8 kBTU/Hour	25.1 kBTU/Hour
Full-Load Efficiency	96.6%	96.4%	96.8%
25% Load Efficiency	94.2%	95.1%	95.7%
Altitude	7380 ft. (2250 m) Maximum Without Derating		
Audible Noise	70dBA @ 1 m Typical		
DIMENSIONS			
Dimensions	27.6" W x 32.8" D x 80.6" H		35.4" W x 32.8" D x 80.6" H
Weight	772 lbs. (350 kg)	860 lbs. (390 kg)	1,080 lbs. (490 kg)
COLOR			
	Munsell N1.5 (Black)		
MONITORING			
	Touchscreen Operator Interface, UPS Status N/O Dry Contacts, RS232 Port, Optional RemotEye® 4 Intelligent Monitoring System		
OPTIONS			
	Internal Batteries, Dual-Input Feed, RemotEye 4 Intelligent Monitoring System, Remote Status Alarm Panel, Air Filters, Spare Parts Kits		
FEATURES			
	Digital Signal Processor (DSP) Control, Fully Digital IGBT Converter & Inverter, High Efficiency Over Wide Load Range, Transformer-Less Design, N+1 & N+N (Up to Four in Parallel) Capability, Dual-Input Feed, Electronic Battery Isolation, RS232 and Dry Contact Interface, Small Footprint, & Lightweight Design, Energy Star® Certified		
STANDARDS			
	UL/CUL 1778 Listed, ISO 9001, ISO 14001, ANSI C62.41 (IEEE 587), FCC Class A-Article 47 - Part 15 B, OSHPD, IBC Code ICC-ES AC156, (CBC) Section 1708A.		
WARRANTY			
	3-Year On-Site Warranty; 5-Year Warranty Available; See Toshiba Warranty Policy for Full Details		
SERVICE			
	24-Hour, 365-Day Technical Support: 1-877-867-8773		



> 300 - 750 kVA

MODEL NUMBER	T90S3S30KS6XSN	T90S3S50KS6XSN	T90S3S65KS6XSN	T90S3S75KS6XSN
Capacity (KVA/KW)	300/300	500/500	650/650	750/750
Topology	True On-Line, Double-Conversion, All-IGBT Technology			
INPUT				
Voltage (Standard)	480V Three-Phase, Three-Wire + Ground Dual Input			
Voltage Range	-20% to +15% (Without Using Battery)			
Power Factor	> 0.99			
Current THD	<3% at 100% Load			
Frequency	60 +/- 10% Hz			
OUTPUT				
Voltage (Standard)	480 V, Three-Phase, Three-Wire + Ground			
Frequency	60 +/- 0.01% Hz			
Voltage Regulation	+/-1%			
Power Factor	1.0 (Unity)			
Power Factor Range	0.9 Lagging to 0.95 Leading			
Voltage THD	<2% at 100% Linear Load, <5% at 100% Non-Linear Load			
Overload Capacity	Inverter: 125% for 10 Minutes, 150% for 60 Seconds, Bypass: 100% for 1 Cycle			
BATTERY				
DC Link	480 V			
ENVIRONMENT				
Temperature Range	32° to 104°F (0° to 40°C)			
Relative Humidity	5% to 95% Non-Condensing			
Heat Rejection	31.7 kBTU/Hour	52.8 kBTU/Hour	68.6 kBTU/Hour	79.2 kBTU/Hour
Full-Load Efficiency	97.0%	97.0%	97.0%	97.0%
25% Load Efficiency	94.4%	94.8%	95.4%	95.5%
Altitude	7380 ft. (2250 m) Maximum Without Derating			
Audible Noise	70dBA @ 1 m Typical		71dBA @ 1 m Typical	
DIMENSIONS				
Dimensions	51.2" W x 32.8" D x 80.7" H	70.9" W x 32.8" D x 80.7" H	90.6" W x 32.8" D x 80.7" H	90.6" W x 32.8" D x 80.7" H
Weight	2,260 lbs. (1026 kg)	3,300 lbs. (1497 kg)	3,300 lbs. (1497 kg)	4,250 lbs. (1928 kg)
COLOR				
	Munsell N1.5 (Black)			
MONITORING				
	Touchscreen Operator Interface, UPS Status N/O Dry Contacts, RS232 Port, Optional RemotEye 4 Intelligent Monitoring System			
OPTIONS				
	Internal Batteries, Dual-Input Feed, RemotEye 4 Intelligent Monitoring System, Remote Status Alarm Panel, Air Filters			
FEATURES				
	Digital Signal Processor (DSP) Control, Fully Digital IGBT Converter & Inverter, High Efficiency Over Wide Load Range, Transformer-Less Design, N+1 & N+N (Up to Eight in Parallel) Capability, Dual-Input Feed, Electronic Battery Isolation, RS232 and Dry Contact Interface, Small Footprint, & Lightweight Design, Energy Star Certified			
STANDARDS				
	UL/CUL 1778 Listed, ISO 9001, ISO 14001, ANSI C62.41 (IEEE 587), IEC 62040-2 Cat. C3			
WARRANTY				
	3-Year On-Site Warranty; 5-Year Warranty Available; See Toshiba Warranty Policy for Full Details			
SERVICE				
	24-Hour, 365-Day Technical Support: 1-877-867-8773			



> 1000-2000 kVA

MODEL NUMBER	T90S3S01MS6XSN	T901H1D3MWWW-C	T901H1D5MWWW-C	T901H1D6MWWW-C	T901H2D0MWWW-C
Capacity (KVA/KW)	1000/1000	1330/1330	1500/1500	1660/1660	2000/2000
Topology	True On-Line, Double Conversion, Advanced Multi-Level IGBT Technology				
INPUT					
Voltage (Standard)	480V Three-Phase, Three-Wire + Ground Dual Input				
Voltage Range	-20% to +15% (Without Using Battery)				
Power Factor	>0.99			>0.98	
Current THD	<3% at 100% Load				
Frequency	60 +/- 10% Hz				
OUTPUT					
Voltage (Standard)	480 V, Three-Phase, Three-Wire + Ground				
Frequency	60 +/- 0.01% Hz				
Voltage Regulation	+/-1%				
Power Factor	1.0 (Unity)				
Power Factor Range	0.7 Lagging to 0.8 Leading				
Voltage THD	<2% at 100% Linear Load, <5% at 100% Non-Linear Load				
Overload Capacity	Inverter: 125% for 10 Minutes, 150% for 60 Seconds, Bypass: 1000% for 1 Cycle				
BATTERY					
DC Link	480 V				
ENVIRONMENT					
Temperature Range	32° to 104°F (0° to 40°C)				
Relative Humidity	5% to 95% Non-Condensing				
Heat Rejection	112.8 kBTU/Hour	159.7 kBTU/Hour	180.1 kBTU/Hour	199.4 kBTU/Hour	240.2 kBTU/Hour
Full-Load Efficiency	96.8%	96.6%	96.6%	96.6%	96.6%
25% Load Efficiency	96.3%	96.1%	96.1%	96.1%	96.1%
Altitude	6500 ft. (1980 m) Maximum Without Derating				
Audible Noise	71dBA @ 1 m Typical	72dBA @ 1 m Typical	73dBA @ 1 m Typical	73dBA @ 1 m Typical	74dBA @ 1 m Typical
DIMENSIONS					
Dimensions	118.2" W x 35.5" D x 80.7" H	167.3" W x 35.5" D x 80.7" H	190.9" W x 35.5" D x 80.7" H	198.8" W x 35.5" D x 80.7" H	222.4" W x 35.5" D x 80.7" H
Weight	6,283 lbs. (2850 kg)	9,590 lbs. (4350 kg)	11,354 lbs. (5150 kg)	11,795 lbs. (5350 kg)	13,558 lbs. (6150 kg)
COLOR					
	Munsell N1.5 (Black)				
MONITORING					
	Touchscreen Operator Interface, UPS Status N/O Dry Contacts, RS232 Port, Optional RemotEye 4 Intelligent Monitoring System				
OPTIONS					
	Internal Batteries, Dual-Input Feed, RemotEye 4 Intelligent Monitoring System, Remote Status Alarm Panel, Air Filters				
FEATURES					
	Digital Signal Processor (DSP) Control, Fully Digital IGBT Converter & Inverter, High Efficiency Over Wide Load Range, Transformer-Less Design, N+1 & N+N (Up to Eight in Parallel) Capability, Dual-Input Feed, Electronic Battery Isolation, RS232 and Dry Contact Interface, Small Footprint, & Lightweight Design, Energy Star Certified				
STANDARDS					
	UL/CUL 1778 Listed, ISO 9001, ISO 14001, ANSI C62.41 (IEEE 587), IEC 62040-2 Cat. C3				
WARRANTY					
	3-Year On-Site Warranty; 5-Year Warranty Available; See Toshiba Warranty Policy for Full Details				
SERVICE					
	24-Hour, 365-Day Technical Support: 1-877-867-8773				

FLEXIBLE BY DESIGN

The G9000 is the most efficient double-conversion UPS on the market with less space per kilowatt than any similar-capacity UPS. It delivers the utmost in design flexibility and can provide the ideal solution, regardless of the user's backup power needs.

> SINGLE MODULE

- Single- or Dual-Source Input
- DC-to-DC Isolation
- Internal Hybrid Static Bypass Circuit
- Controllable at Local LCD Panel or Through Customer Supplied Interface
- Monitor UPS Locally or Remotely

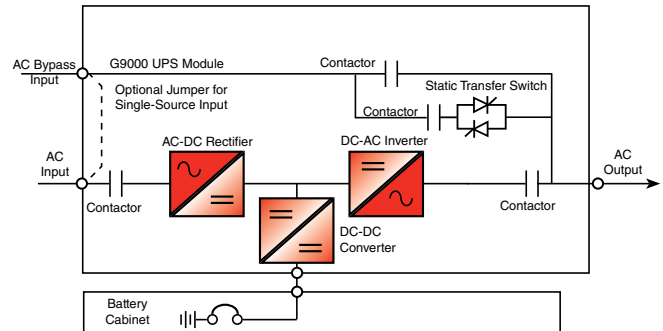

> MULTI-MODULE

- Parallel Units without Additional Control Circuitry
- Load Capacity 100 kVA to 12 MVA
- Distributed Bypass Eliminates Potential Single Point of Failure in Bypass Mode
- Tie Cabinet Does Not Require Special Control Circuitry for Future Expansion
- Individual Modules & Entire System Monitored & Controlled via Local Displays in Each UPS or Through Optional System Display in TTC
- Load Balance & Synchronization Intelligence are Self-Contained in Each UPS Module & Not in External Sync Controller, Increasing System Reliability & Making Expansion/Reconfiguration of Parallel Multi-Module Systems Easy

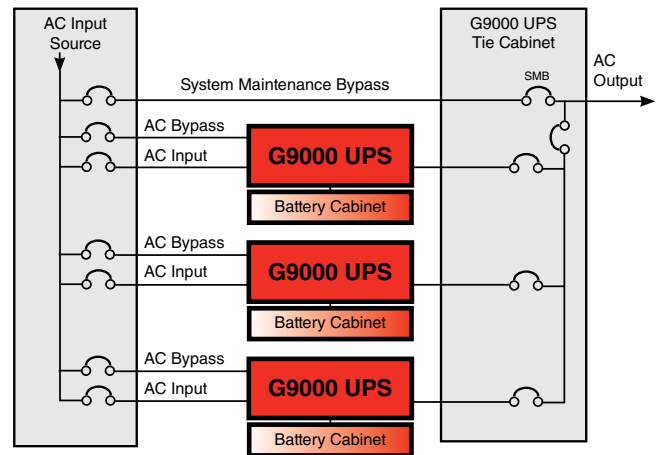

> APPLICATIONS

- Data Centers
- Financial Institutions
- Call Centers
- Co-Locations



TOSHIBA POWER ELECTRONICS DIVISION:

- Uninterruptible Power Systems
- SCiB™ Lithium Ion Batteries
- Energy Management Systems
- Remote Monitoring
- High Power Chargers
- Containerized Solutions

TOSHIBA
Leading Innovation 

www.toshibaups.com